

SX-4289

LH3 Steering Sensor with Torque and Position Output

The LH3 torque and position sensor is ideally suited for demanding Electric Power Steering systems.

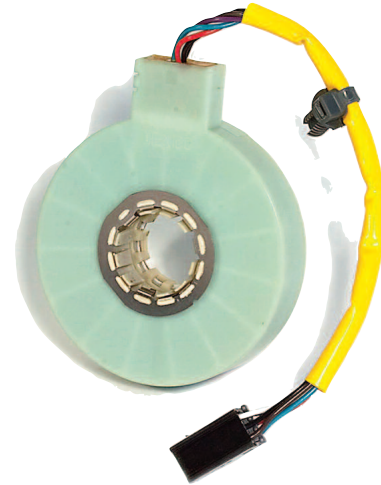

ELECTRICAL¹

Torque signal linearity	±3%
Torque hysteresis	0.5%
Torque signal microgradient	1% ±0.6% over 0.2°
Torque signal sensing angled	±8°
Position signal linearity	±1.5%
Position signal microgradient	1.111% ±0.4% over 2°
Total resistance	400 Ω ±30%

MECHANICAL

Torque Mechanical Travel	±11°
Turning Torque (rotor to rotor)	0.03 NM Max.
Turning Torque (position rotor to housing)	0.06 NM Max.
Position Mechanical Travel	Continuous
Weight	95 grams maximum

ENVIRONMENTAL

Operating Temperature Range	-40°C to +85°C
Shock	14 ms half-sine at 300 m/s ²
Vibration	10 to 55 Hz with 1 mm P-P constant displacement, 120 hours each of 3 planes
Torque Rotational Life	1 million cycles
Position Rotational Life	1 million cycles
Storage Temperature Range	-40°C to +105°C

¹ Specifications subject to change without notice. Complete specifications and test methods per BI Technologies specification HEP 32056

OUTPUT CHARTS

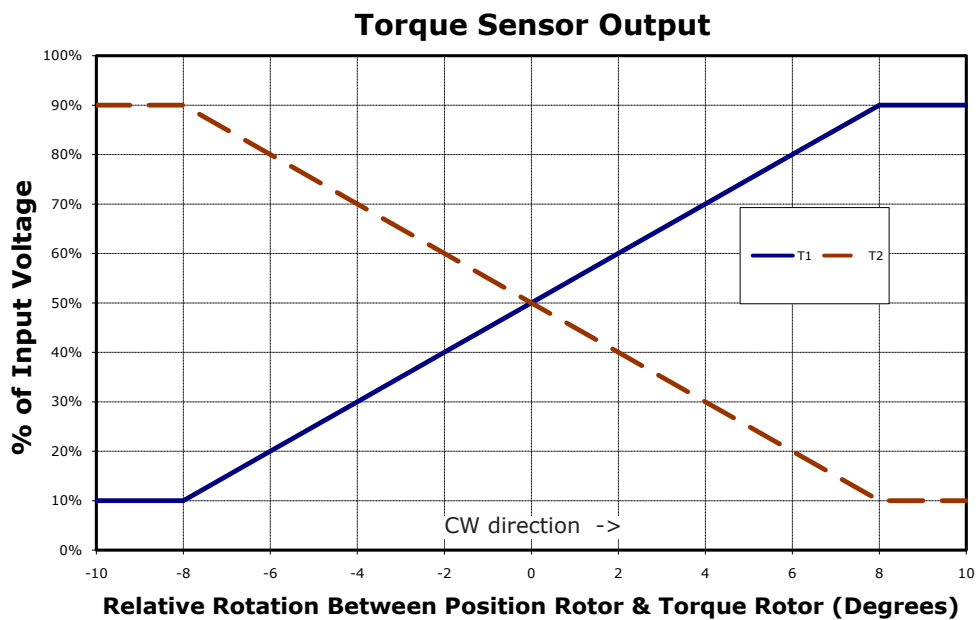
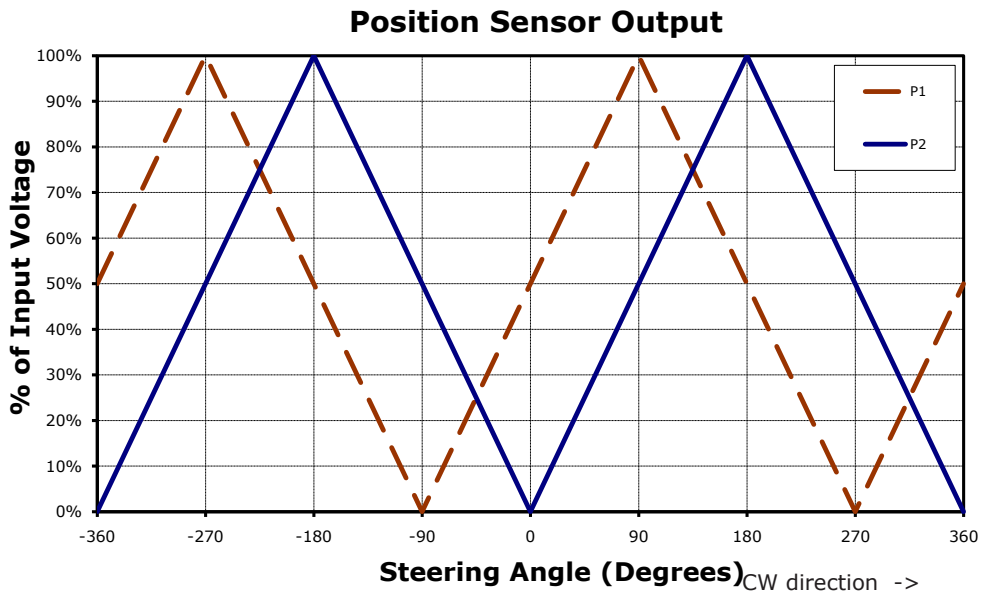

SX-4289

OUTLINE DRAWING

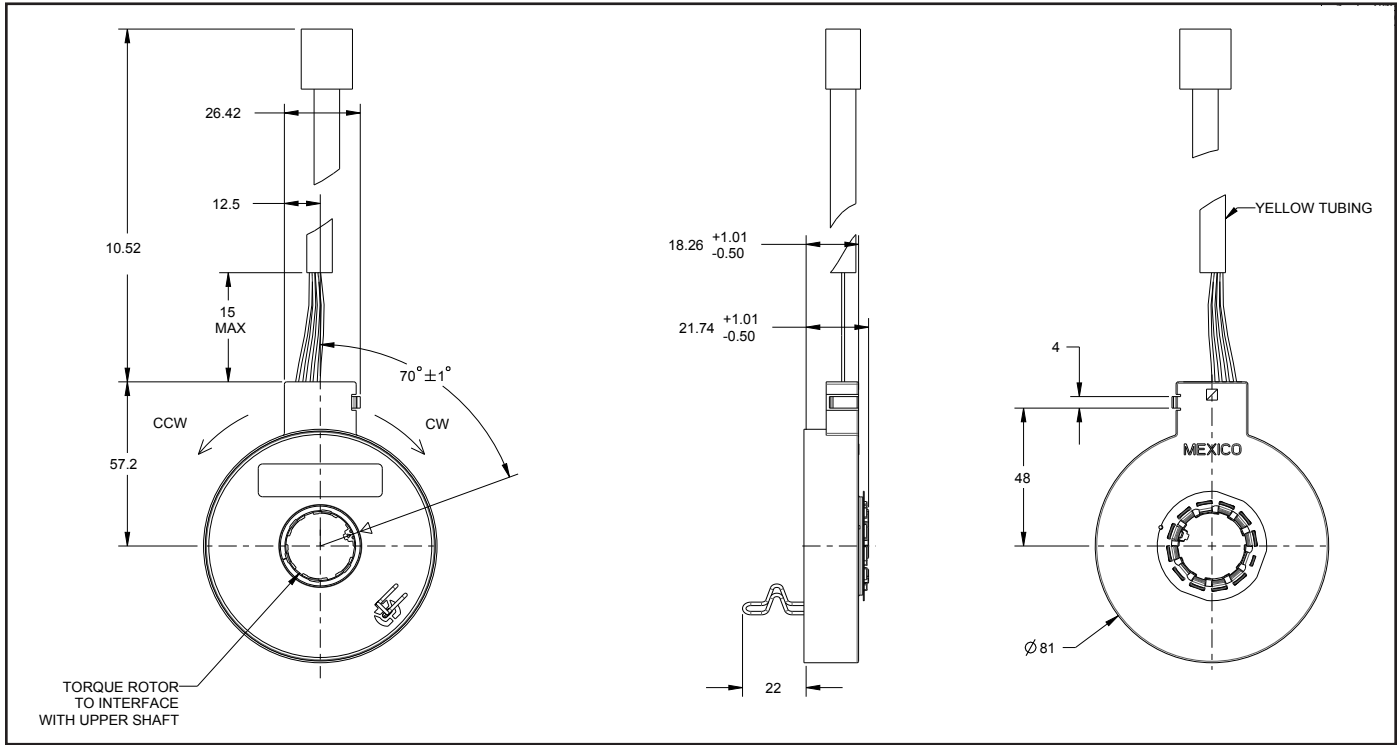

Tolerances ± 0.25 mm unless otherwise specified. See drawing # 122-4289-80 for details.

PINOOTS

PIN OUTS-6 PIN CONNECTOR		
PACKARD 15336723		
1	2	3
4	5	6
PIN No.	SIGNAL	WIRE COLOR
1	T1	BLUE
2	Vcc	RED
3	T2	PURPLE
4	P1	BROWN
5	GND	BLACK
6	P2	WHITE

SX-4289

RECOMMENDED INTERFACE

