

Model EN12  
 12mm Rotary Encoder  
 2 Bits Gray Code  
 Incremental/Contacting Type  
 Metal Bushing/Plastic Shaft  
 Push-on Switch Option  
 RoHS Compliant

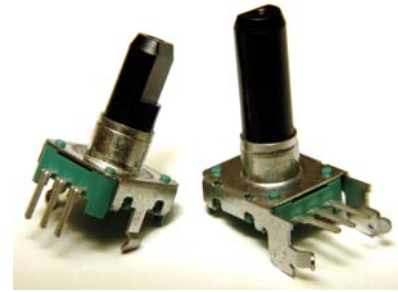

### MODEL STYLES

Top Adjust, with Switch	EN12-HS
Top Adjust, without Switch	EN12-HN
Side Adjust, with Switch	EN12-VS
Side Adjust, without Switch	EN12-VN

### ELECTRICAL<sup>1</sup>

Pulses ( Per Revolution )	12 & 24
Closed Circuit Resistance, Ohms	3 Ohms, max.
Contact Rating	1mA/ 5Vdc
Operating Current, Maximum	1mA
Dielectric Strength	300Vac/ 1mA, 1 minute
Insulation Resistance, Minimum	100M ohms at 250Vdc/ 1mA
Sliding Noise ( at 60 RPM )	2.0ms max.
Contact Bounce ( at 15 RPM)	5.0ms max.
Operating Speed ( RPM )	100 RPM max.
Switch Power Rating	10mA/ 5Vdc
Switch Contact Resistance	100 milliohms
Actual Electrical Travel, Nominal	Continuous

### MECHANICAL

Total Mechanical Travel	Continuous
Detents (per Revolution)	0, 12, 24
Rotational Torque of Detent, Maximum	1.4 oz-in
Switch Operating Force	550 gf
Switch Travel	0.5mm

<sup>1</sup> Specifications subject to change without notice.

# Model EN12

## ENVIRONMENTAL

Operating Temperature Range

-30°C to +85°C

Rotational Life

30,000 cycles

## ORDERING INFORMATION<sup>2</sup>

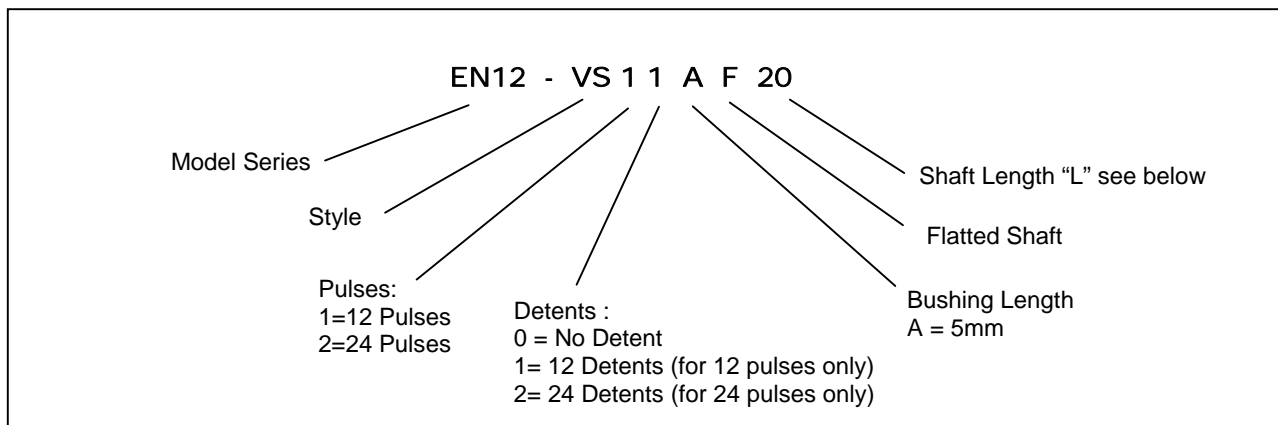

### Shaft Length Options

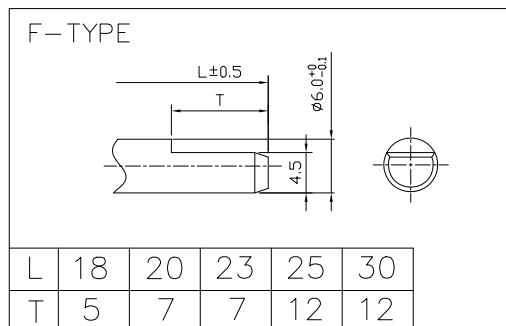

**18 Length = 17.5mm**

**23 Length = 22.5mm**

## CIRCUIT DIAGRAM

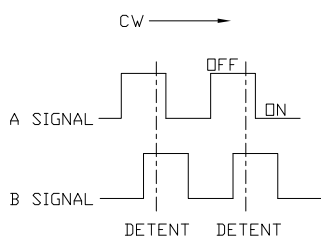

<sup>2</sup> Contact our customer service for custom designs and features.

