

# Nichrome Resistor Networks on Silicon Substrates

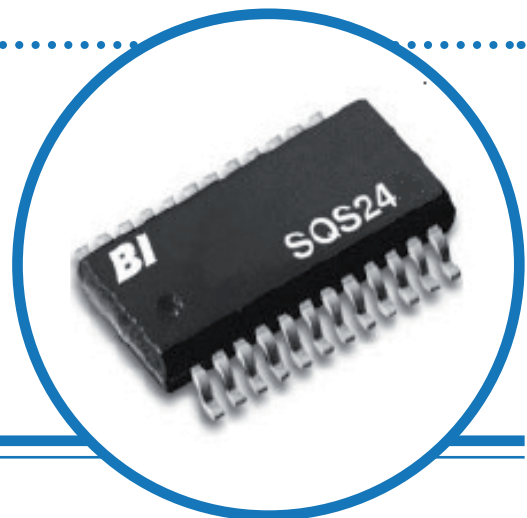

S Series: SQSxxA<sup>1</sup>, SQSxxB, SSNxxA, SSNxxB, SSWxxA, SSWxxB, SPDxxA, SPDxxB

**Isolated and bussed circuits**  
**Thin film resistor network**  
**RoHS compliant**



## Features

Precision Nichrome Resistors on Silicon	Passivation coating provides protection in humid environments
Industry Standard Packaging	JEDEC 95
Ratio Tolerances	< ± 0.05%
TCR Tracking Tolerances	< ± 5 ppm/°C

## Schematics

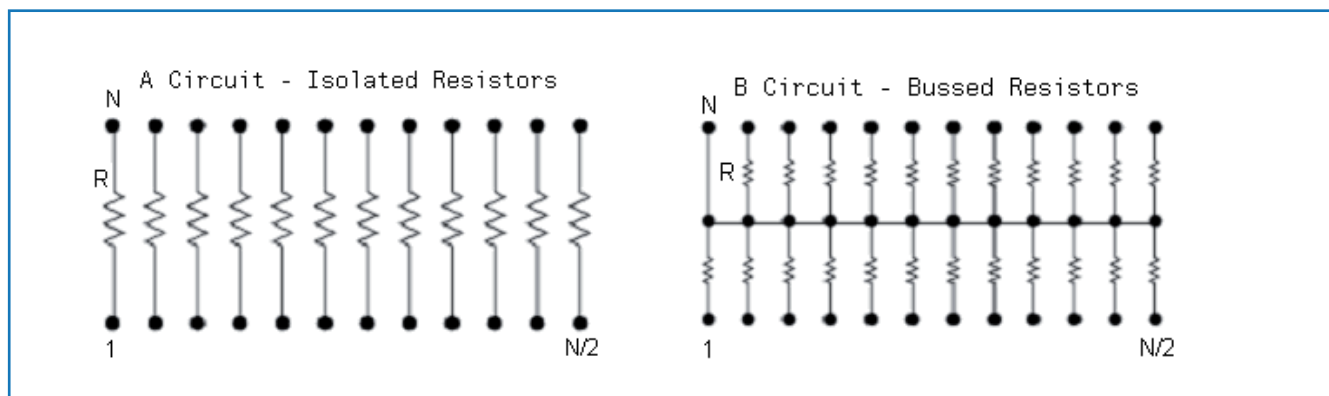

## Electrical<sup>2</sup>

Standard Resistance Range <sup>3</sup>	1K ohms to 100K ohms (Isolated) 1K ohms to 30K ohms (Bussed)
Resistor Tolerances	± 0.25%
Ratio Tolerances	± 0.05%
TCR	TCR table
Operating Temperature Range	-55°C to +125°C
Interlead Capacitance	< 2 pF
Insulation Resistance	≥ 10,000 Megohms
Maximum Operating Voltage	100 Vdc or v PR
Noise, Maximum (MIL-STD-202, Method 308)	-25 dB
Resistor Power Rating at 70°C	0.1 Watts

1 xx denotes package pin count. Reference package type section in this data sheet for description.

2 Specifications subject to change without notice.

3 E96 codes available.

### General Note

TT electronics reserves the right to make changes in product specification without notice or liability. All information is subject to TT electronics' own data and is considered accurate at time of going to print.



www.bitechnologies.com www.irctt.com www.welwyn-tt.com

## Power Derating Curve & Package Power, Watts @ 70°C, Max.<sup>4</sup>

QSOP			SOIC (Narrow)			SOIC (Wide)			P-DIP		
16	20	24	8	14	16	16	20	24	8	14	16
0.6	0.7	0.8	0.4	0.7	0.8	1.0	1.2	1.2	0.4	0.6	0.8

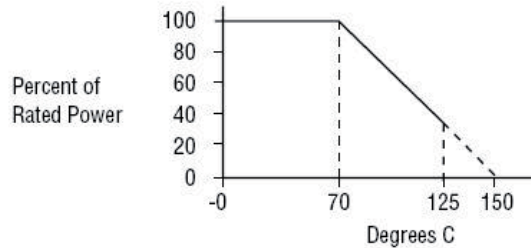

## Environmental (Mil-R-83401)

Thermal Shock plus Power Conditioning	ΔR 0.25%
Short Time Overload	ΔR 0.1%
Terminal Strength	ΔR 0.1%
Moisture Resistance	ΔR 0.2%
Mechanical Shock	ΔR 0.25%
Vibration	ΔR 0.25%
Low Temperature Operation	ΔR 0.05%
High Temperature Exposure	ΔR 0.1%
Resistance to Solder Heat	ΔR 0.1%
Marking Permanency	Per MIL-STD-202, Method 215
Flammability	UL-94V-0 Rated
Storage Temperature Range	-55°C to +125°C

## Mechanical

Lead Plating	100 matte Tin (RoHS)
Lead Material	Copper Alloy
Lead Configuration	Gull Wing
Lead Coplanarity	0.004" (0.102 mm)
Substrate Material	Silicon
Resistor Material	Passivated Nichrome
Body Material	Molded Epoxy

<sup>4</sup> Maximum power per resistor @ 70°C is 100 mW, not to exceed package power.

### General Note

TT electronics reserves the right to make changes in product specification without notice or liability. All information is subject to TT electronics' own data and is considered accurate at time of going to print.

## Ordering Information <sup>5</sup>

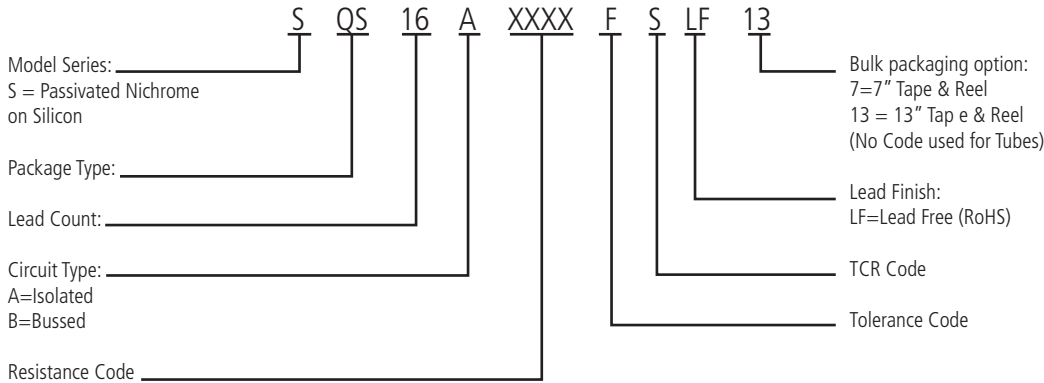

## Package Type

	Package Codes	Lead count	Mechanical Outline
QSOP	QS	16, 20, 24	MO-137
SOIC Narrow Body	SN	8, 14, 16	MS-012
SOIC Wide Body	SW	16, 20, 24	MS-013
P-DIP	PD	8, 14, 16	MS-001

## Resistance <sup>5</sup>

First 3 digits are significant. Fourth digit denotes number of trailing zeros. For values less than 100, use "R" to denote a decimal point. Example, 51 and 10000 ohms are coded as 51R0 and 1002 respectively. Standard values follow E96.

## Resistance Tolerance

Accuracy Code at 25°C	CA	CB	D	FA	F	G	J
Absolute Resistance Tolerances (%)	± 0.25	± 0.25	± 0.5	± 1.0	± 1.0	± 2.0	± 5.0
Ratio Tolerances (R1 Ref) (%)	± 0.05	± 0.1	± 0.1	± 0.05	± 1.0	N/A	N/A

## Temperature Coefficient of Resistance (TCR)

TCR Code (-55°C to 125°C)	Q	P	S	L
Absolute (ppm/°C)	± 25	± 50	± 100	± 200
Tracking (R1 Ref) (ppm/°C)	± 5	± 5	N/A	N/A

<sup>5</sup> Contact customer service for custom designs and features

### General Note

TT electronics reserves the right to make changes in product specification without notice or liability. All information is subject to TT electronics' own data and is considered accurate at time of going to print.

## Bulk Packaging Options

Model + Pin Count	Quantity		
	7" Reel	13" Reel	Tubes
SQS16	1000	2500	100
SQS20	1000	2500	50
SQS24	1000	2500	50
SSN08	1000	2500	100
SSN14	500	2500	50
SSN16	500	2500	50
SSW16	500	1500	50
SSW20	500	1500	38
SPD08	N/A	N/A	50
SPD14	N/A	N/A	25
SPD16	N/A	N/A	25

## Typical Marking

The diagrams illustrate the marking on the front and back of resistor networks for different models:

- SPD16A47R0:** Front marking includes the BI logo, part number SPD16A47R0, date code YYMM, and lot number X0032.
- SPD08:** Front marking includes the BI logo, part number SPD08 A1003, date code YYMM, and lot number X0021.
- SQS16:** Front marking includes the BI logo, part number SQS16 B3901, and date code YYMM. The lot number is printed on the back side.
- SSN16:** Front marking includes the BI logo, part number SSN16 B1500, date code YYMM, and lot number X4212.
- SSH08:** Front marking includes the BI logo, part number SSH08 B2001, and date code YYMM. The lot number is printed on the back side.

### General Note

TT electronics reserves the right to make changes in product specification without notice or liability. All information is subject to TT electronics' own data and is considered accurate at time of going to print.