

# 920, 930, 940 SERIES

## Precision Motor Potentiometers

BI Motor Potentiometers use a precision potentiometer connected to a DC motor by a gear box and clutch. There are eight potentiometer types and 15 gear ratios available combined with a 10,700 RPM motor.

In addition, motor potentiometers with special features such as center-taps, multi-taps, special shafts, and special gear ratios, etc., can be provided on special orders. Several potentiometer sections can be ganged on a single rotor potentiometer shaft.



### SPECIFICATIONS

Motor Potentiometer Model	922	927	929	931
Potentiometer Model	6671	8146	8211	A
# of Turns	1	10	1	10
Element Type	Conductive Plastic	Hybrid	Hybrid	Wirewound
Potentiometer Mounting Style	Bushing	Bushing	Bushing	Bushing
Resistance Range, Ohms	1K-300K	1K-100K	1K-25K	10-500K
Diameter	2"	7/8"	2"	1 - 13/16"
Linearity	±0.25%	±0.25%	±0.5%	<300Ω: ±0.5% ≥300Ω: ±0.25%
No. of Gangs, Max.	3	2	3	3

Motor Potentiometer Model	933	936	937	949
Potentiometer Model	C	7283	7286	5611
# of Turns	3	10	10	1
Element Type	Wirewound	Wirewound	Wirewound	Wirewound
Potentiometer Mounting Style	Bushing	Servo	Bushing	Bushing
Resistance Range, Ohms	100-100K	100-100K	100-100K	1K - 50K
Diameter	1-13/16"	7/8"	7/8"	2"
Linearity	±0.5% ≥1KΩ: 0.20%	≤75Ω: ±0.50%	±0.25%	<50Ω: ±1.0% ≥50Ω: ±0.5%
No. of Gangs, Max.	3	2	2	3

Specifications subject to change without notice.  
Refer to potentiometer data sheet for complete specifications.

## MOTOR SPECIFICATIONS

Rotor Temperature, °C	22
Input Voltage Range, Vdc	Vis to 9.0
Input Voltage, Nominal, Vdc	6.0*
Power Input @ Stall (6 Vdc), Watts	1.8
No Load Current, mA	≤7
Armature Resistance, Ohms	20
No Load Speed @ Max. Volts, RPM	16,000
No Load Speed (6.0 Vdc, RPM)	10,700
Mechanical Time constant @ Max. Supply Voltage, Sec.	0.032
Starting Voltage, Vdc	0.3
Torque Constant, oz.-in.	0.749
Torque Stall (6.0 Vdc), oz.-in. Max.	0.22
Torque Continuous Duty (Gear Box), oz.-in. Max.	3
Moment of Inertia, oz.-in. /Sec <sup>2</sup>	5.6 x 10 <sup>-6</sup>
Motor Pot Life Expectancy @ Rated Torque, Hours	5,000
Slip Friction Setting, oz.-in., Nominal	12
Life Reduction per Load Torque Beyond Rating, Estimated Hours	643 (T <sub>L</sub> <sup>-3</sup> )

\*Input voltage in continuous stall and 22°C ambient.

## GEAR RATIO SPECIFICATIONS

Gear Ratio (N)	Output Speed (RPM)	Efficiency (e)	Backlash Max. (B)	Direction(D)**
41:1†	261	.73	4°	CW
76:1	141	.66	4°	CCW
141:1†	76	.66	4°	CCW
262:1†	41	.59	4°	CW
485:1	22	.59	4°	CW
900:1	12	.53	4°	CCW
1,670:1	6.4	.53	4°	CCW
3,101:1	3.5	.48	4°	CW
5,752:1	1.9	.48	4°	CW
10,683:1	1.0	.43	4°	CW
19,813:1	0.54	.43	4°	CCW
36,796:1	0.29	.39	4°	CW
68,245:1	0.17	.39	4°	CW
126,741:1	0.08	.35	4°	CCW
235,067:1	0.05	.35	4°	CCW

\*\* Direction of shaft rotation with "+" voltage to red lead.

† Stocked ratios.

**PERFORMANCE**

**Output Speed vs. Gear Ratio at various Load Torques**

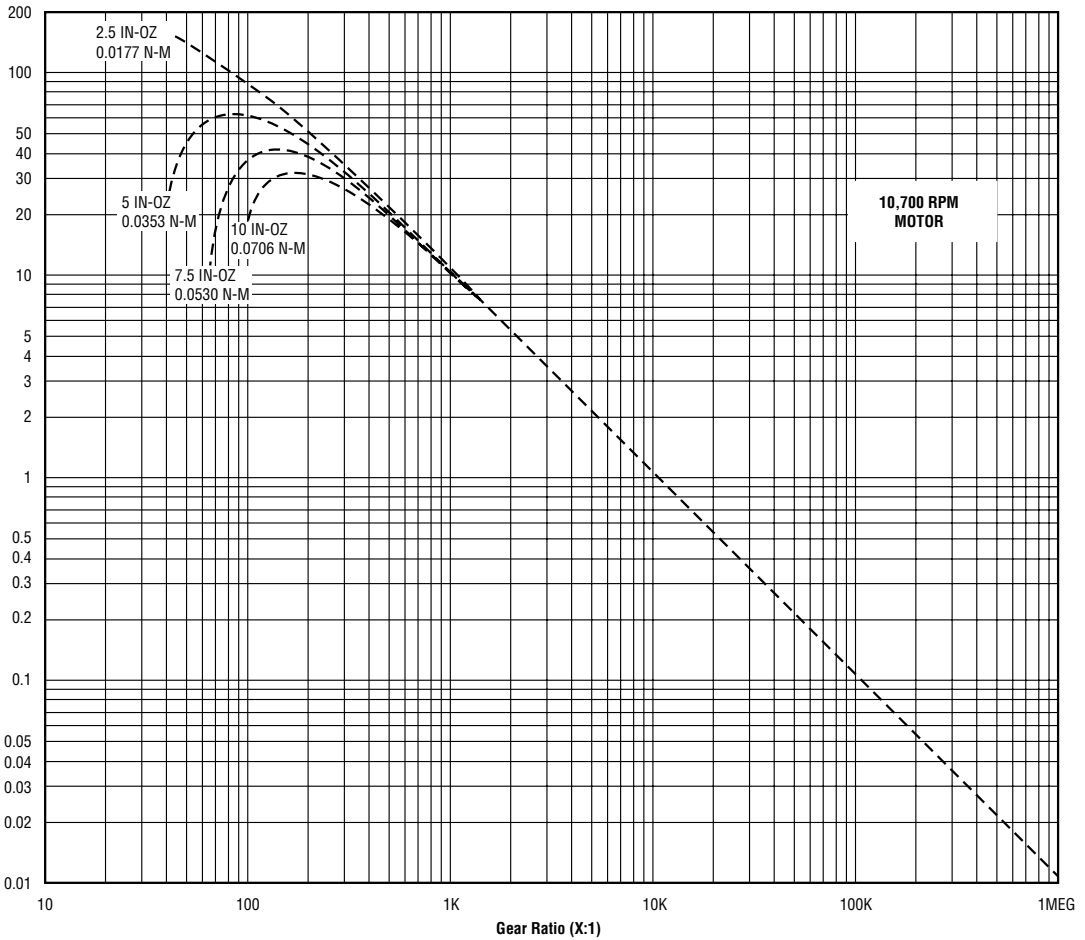

41	76	141	262	485	900	1670	3120	5750	10.7K	19.8K	37K	68.2K	127K	235K
(.73)	(.66)	(.66)	(.59)	(.59)	(.53)	(.53)	(.48)	(.48)	(.43)	(.43)	(.39)	(.39)	(.35)	(.35)

**Specific Ratios (Efficiency)**

**OUTLINE DIMENSIONS (Inch/mm)**

**Models 922, 929 & 949**

(Potentiometer Models 6671 & 5611)

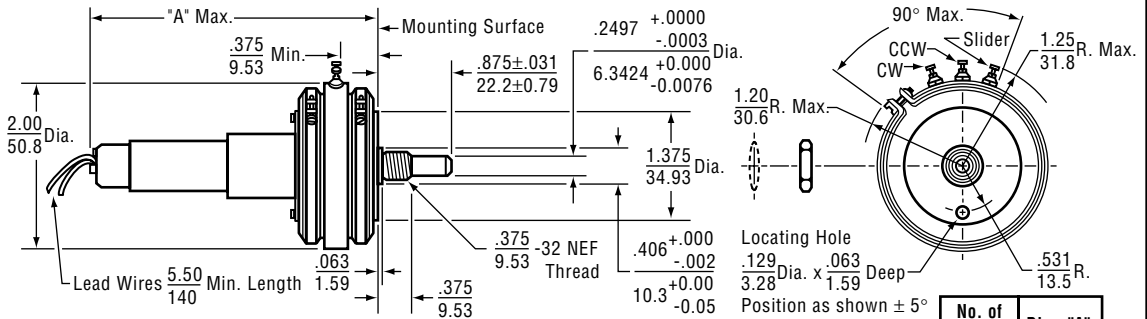

No. of Sections	Dim. "A"
1	3.55 90.2
2	4.11 104
3	4.68 119

**Models 927 & 937**

(Potentiometer Models 8146 & 7286)

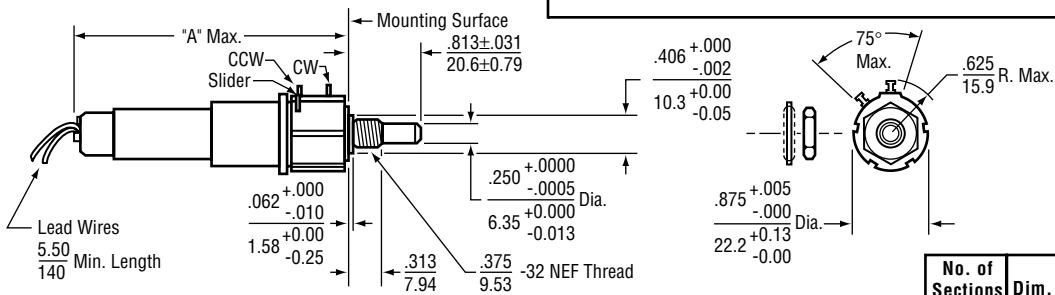

No. of Sections	Dim. "A"
1	3.55 90.2
2	4.11 104

**Model 931**

(Potentiometer Model A)

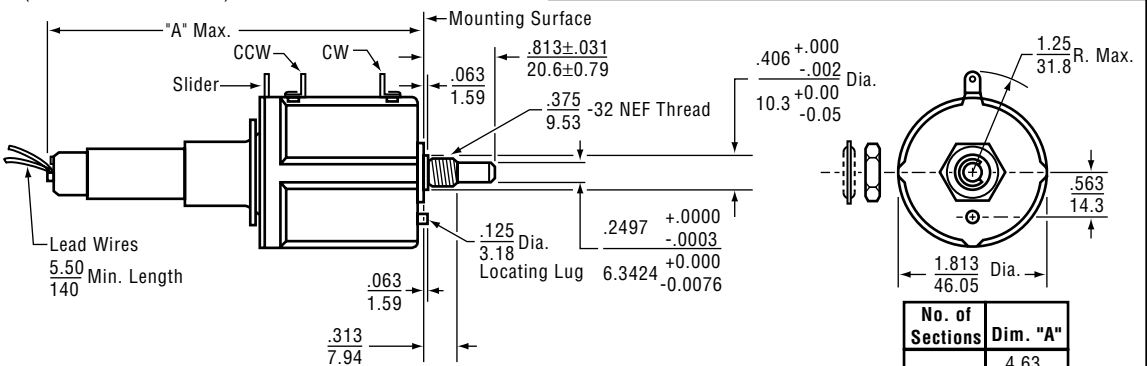

No. of Sections	Dim. "A"
1	4.63 118
2	6.83 174
3	8.73 222

**OUTLINE DIMENSIONS (Inch/mm)**

**Model 933**

(Potentiometer Model C)

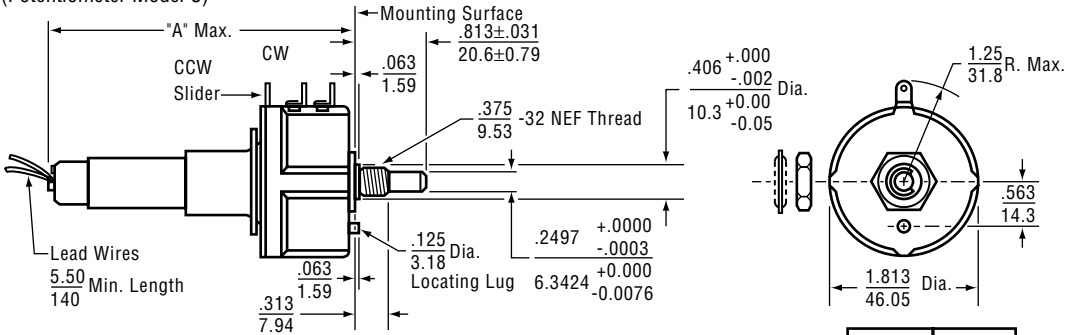

No. of Sections	Dim. "A"
1	3.70 95.8
2	5.05 129
3	6.09 155

**Model 936**

(Potentiometer Model 7283)

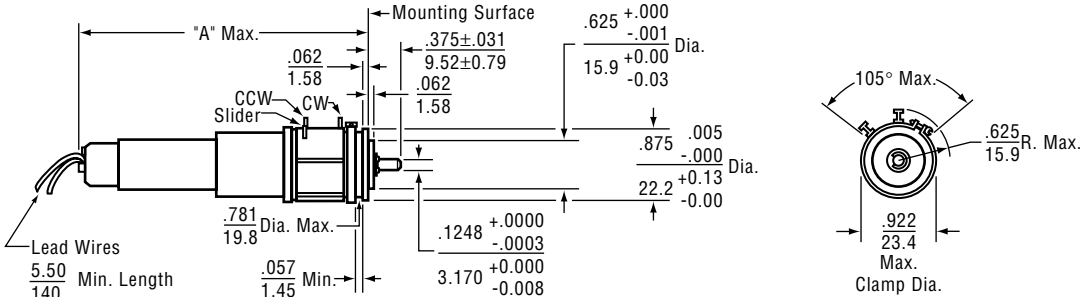

No. of Sections	Dim. "A"
1	3.50 88.9
2	4.19 106



## MOTOR POT AND LOAD PERFORMANCE CALCULATIONS

e	=	Gear ratio Efficiency
J <sub>l</sub>	=	Load inertia (oz. in.-sec <sup>2</sup> )
J <sub>m</sub>	=	Motor inertia (oz. in.-sec <sup>2</sup> )
J <sub>t</sub>	=	Total inertia at motor shaft (oz. in.-sec <sup>2</sup> )
K <sub>t</sub>	=	Motor torque constant (oz. in./A)
N	=	Gear ratio (N:1)
R <sub>a</sub>	=	Armature d-c resistance (ohms)
S <sub>nl</sub>	=	No load motor speed at rated voltage (RPM)
S <sub>o</sub>	=	Slew velocity (RPM)
t	=	Travel time (seconds)
T <sub>l</sub>	=	Load torque (oz. in.) Must include pot
t <sub>m</sub>	=	Mechanical time constant (seconds)
T <sub>s</sub>	=	Motor stall torque at rated voltage (oz. in.)
V <sub>s</sub>	=	Motor no load starting voltage (Vdc)
V <sub>ls</sub>	=	Start torque of motor and load Vdc
V <sub>t</sub>	=	Terminal voltage (Vdc)
θ	=	Degrees traveled

1. To determine motor and load starting voltage:

$$V_{is} = V_s + \frac{6T_l}{eNT_s}$$

2. To determine slew velocity at terminal voltage:

$$S_o = \frac{SnIV_t}{6TsN} \left( Ts - \frac{T_l}{eN} \right)$$

3. To determine gear ratio:

$$N = \frac{SnI}{2S_o} \left( 1 + \sqrt{1 - \frac{4T_l S_o}{TsSnI}} \right)$$

4. To determine degrees traveled:

$$\theta = 6S_o [t - tm(1 + 2.72^{-t/tm})]$$

5. To determine mechanical time constant:

$$tm = \frac{RaJt}{7 \times 10^{-3} Kt^2}$$

Where:

$$Jt = Jm + \frac{Jl}{N^2}$$

## ORDERING INFORMATION

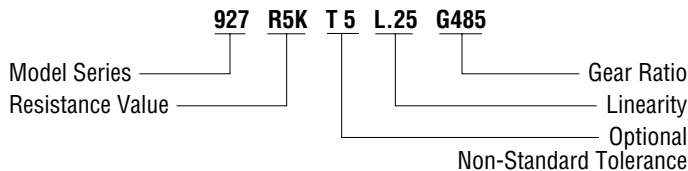

## CIRCUIT DIAGRAM

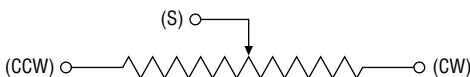

## NOTES

Metric equivalents, based on 1 inch = 25.4mm are rounded to the same number of significant figures as in the original English units and are provided for general information only.

Tolerances unless otherwise specified:  
 Linear = ± .01 inches  
           (.25mm)  
 Angular = ± 2 degrees

