

Model 6120

Position Sensor

7/8" Diameter

Non-Contacting Single Turn

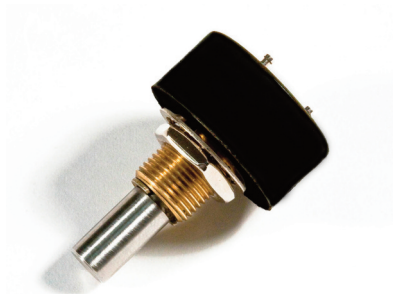

MODEL STYLES AVAILABLE

6121	1/8" Shaft, 1/4" Bushing
6126	1/8" Shaft, 3/8" Bushing
6127	1/4" Shaft, 3/8" Bushing
6120-XXXX	Custom models are available; Contact Customer Service for special features

ELECTRICAL¹

Output Voltage	0.25 Vdc to 4.75 Vdc Typical (see Feature Codes table)
Output Overvoltage Limits	10 Vdc to -0.3 Vdc; output may be shorted to ground or supply without damage
Output Current	±8 mA Max.
Output Load	1 kΩ Min., 10 kΩ Typical
Input Voltage	4.5 to 5.5 Vdc
Supply Voltage Absolute Limits	20 Vdc Max., -10 Vdc Min.
Independent Linearity ²	±0.5% (0.25% Available)
Hysteresis	0.2% Max.
Resolution	0.088° for 360° travel, 0.011° for 45° travel
Supply Current	7.5 mA Typical, 11 mA Max.
Dielectric Strength	750 V rms
Insulation Resistance	1,000 MegΩ Min.
Electrostatic Discharge (ESD)	Passes 2 kV human body model and 15 kV air discharge
Bulk Current Injection (BCI)	Passes 2-500 MHz at 200 mA
Actual Electrical Travel	360° Typical (see Ordering Information)
Temperature Coefficient of Output Voltage	± 20 ppm/°C

MECHANICAL

Total Mechanical Travel	360° Continuous (320° with stop feature)
Bearing	Bearing Bronze Bushing
Weight	0.6 oz. Typical
Static Stop Strength	40 in. oz.
Panel Nut Tightening Torque	25 in. lb. Max.

¹ Specifications subject to change without notice.

² Linearity is measured between 1% and 99% of input voltage.

Model 6120

ENVIRONMENTAL

Operating Temperature Range	-40°C to +125°C
Shock	Per MIL R-39023, 6 ms Saw-tooth 100 G's
Vibration	Per MIL R-39023, 10 G's, 100 to 500 Hz
Moisture Resistance, Powered	Per MIL 202G, Method 106G
Rotational Life	10 million shaft revolutions
Storage Temperature Range	-55°C to +125°C

ORDERING INFORMATION

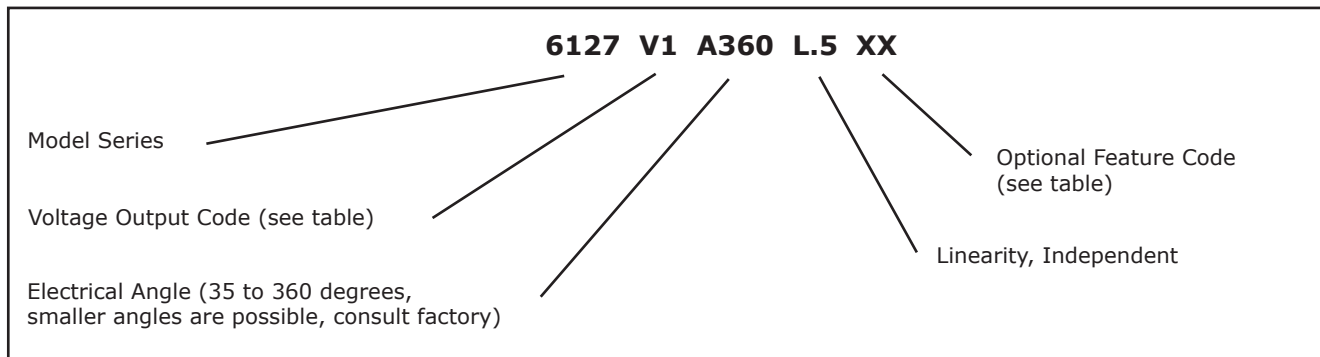

FEATURE CODES

Voltage Output Codes		Optional Feature Codes	
V0	≤ 0.15 Vdc to ≥ 4.8 Vdc	ST	Stop (320°)
V1	0.2 Vdc to 4.8 Vdc	FS	Flatted Shaft (slot standard)
V2	0.25 Vdc to 4.75 Vdc	LT	Linearity Data
V3	0.5 Vdc to 4.5 Vdc	SL	Shaft Lock
V4	0.75 Vdc to 4.25 Vdc	CW	Reverse Direction
V5	1 Vdc to 4 Vdc		

When V0 is used the angle specified is the theoretical angle over which the output would vary if the output could actually reach 0% and 100% of Vcc.

NOTES

This model series of non-contacting sensors uses a magnetic field and hall effect sensor to measure rotational position. Strong external magnetic fields will add to the sensor magnetic field and possibly influence the accuracy of the sensor. If the proposed application includes strong external

magnetic fields, the sensor can be shielded to mitigate the adverse effect. Contact customer service for applications that require shielding.

Model 6120

OUTLINE DRAWING

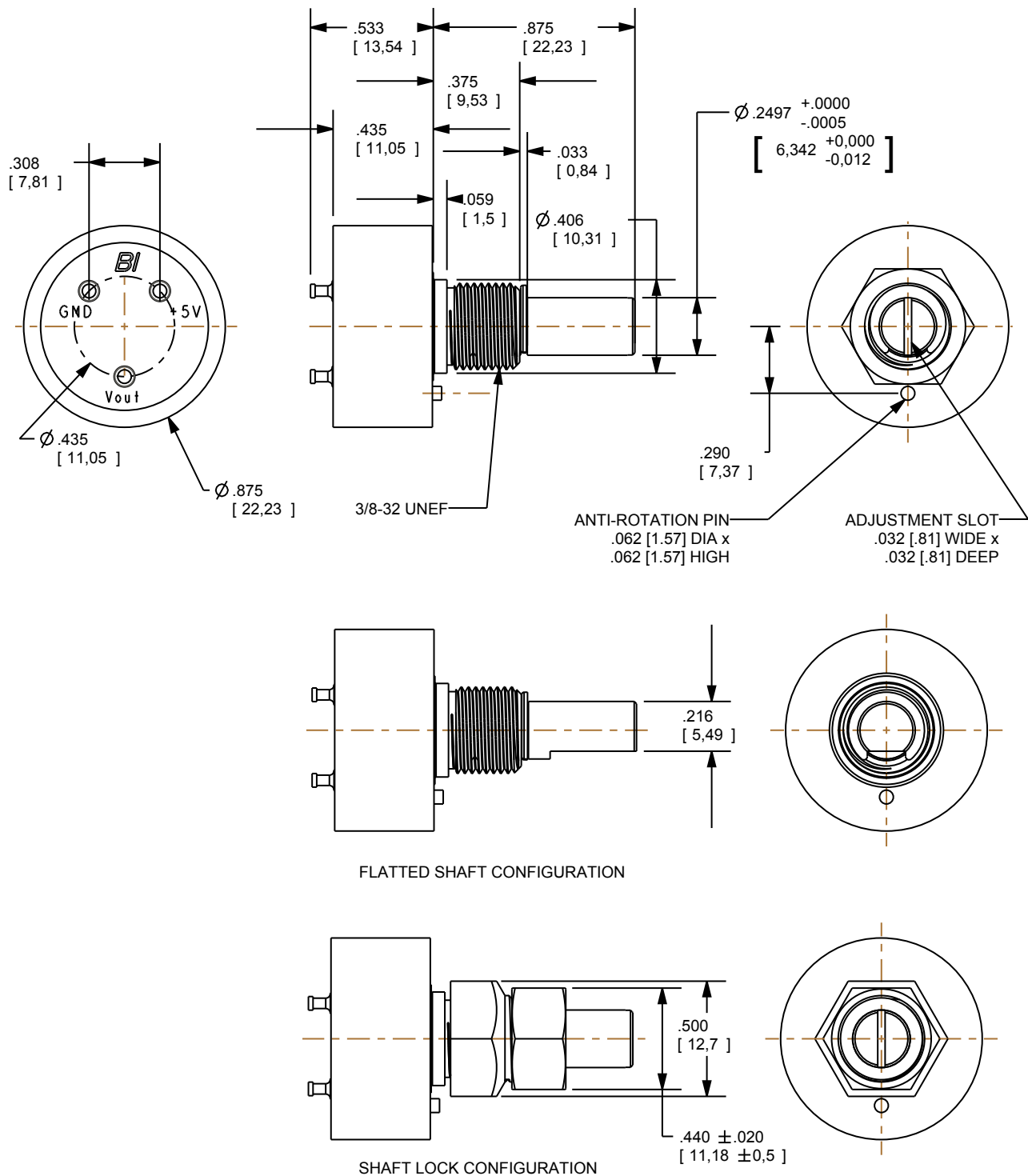

NOTES:

1. UNIT SHIPS WITH NUT AND WASHER (NOT SHOWN).
2. FOR SLOTTED OR FLATTED SHAFT, OUTPUT IS AT 50% IN POSITION SHOWN.
3. DIMENSIONS: INCHES [mm].
4. TOLERANCES: $\pm .015$ [.38] UNLESS NOTED.